

BEHÄLTER KG BREMEN

Behälter KG Bremen GmbH & Co.
Theodor-Barth-Str. 25
28307 Bremen - Germany
Tel. +49 (0) 421 34 85 114
E-Mail: mail@behaelter-kg.de

| | |
|---|-------------------------------|
| Construction date: 2015 | Stock nr.: EW9229V6N/ID10.898 |
| Material vessel: AISI 316/AISI 304 | Capacity: 200 L |
| Workpressure: ATM. | Workpressure coil: |
| Maximal density: 1,2 kg/dm ³ | Serial nr.: 115 095 07-01 |

BEHÄLTER KG BREMEN

Behälter KG Bremen GmbH & Co.
Theodor-Barth-Str. 25
28307 Bremen - Germany
Tel. +49 (0) 421 34 85 114
E-Mail: mail@behaelter-kg.de

| | |
|---|-------------------------------|
| Construction date: 2015 | Stock nr.: EW9229V6N/ID10.932 |
| Material vessel: AISI 316/AISI 304 | Capacity: 200 L |
| Workpressure: ATM. | Workpressure coil: |
| Maximal density: 1,2 kg/dm ³ | Serial nr.: 115 095 07-02 |

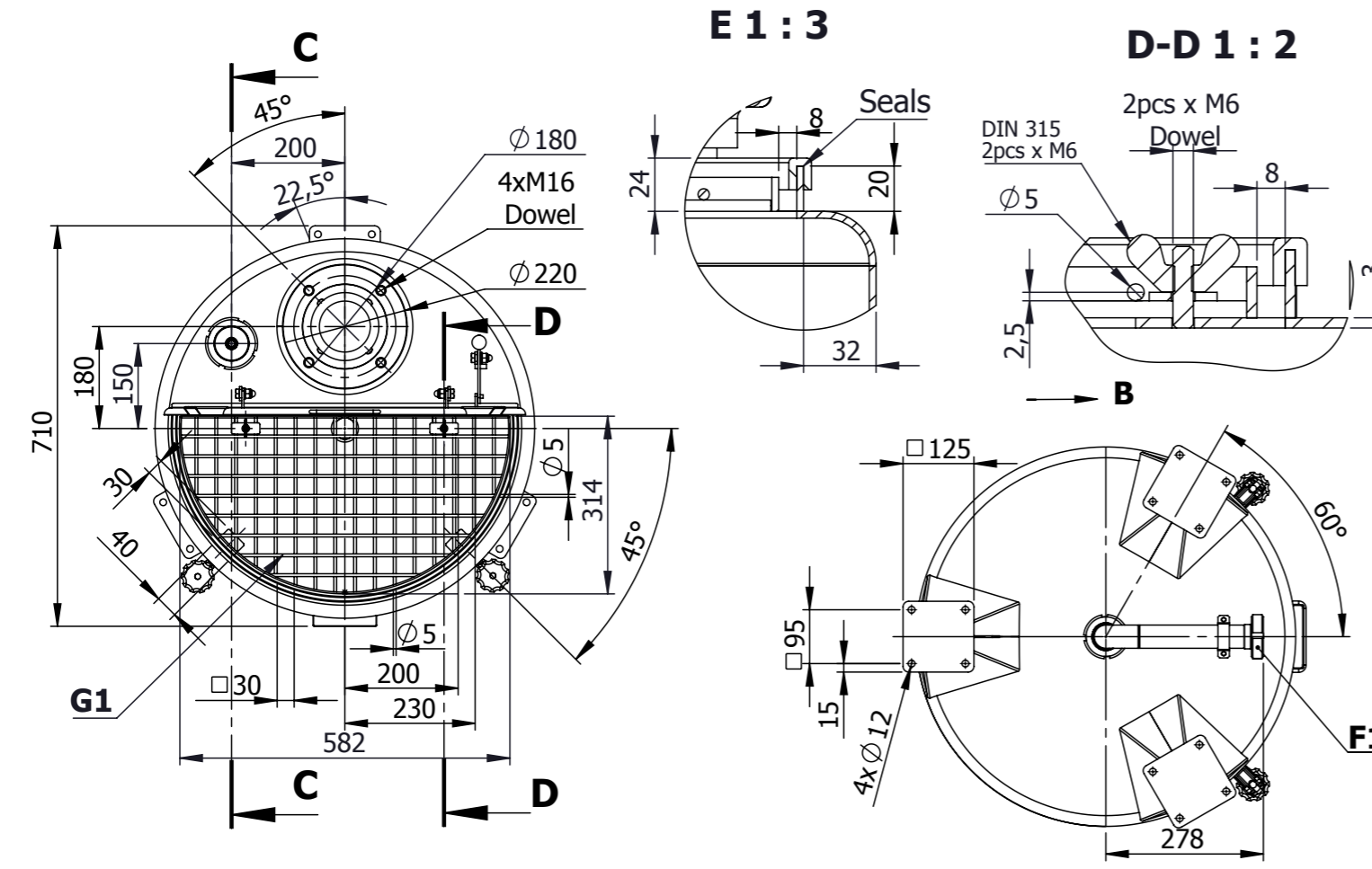

Schnellmischer:
 1. RW9248V6N 0,37kW 1500rpm 400V
 2. RW9250V6N 0,12kW 680rpm 400V

| Item | Description | PN | DN | Qty. |
|-----------|---|------|------|------|
| | | MPa | mm. | |
| A1 | LEG ON ANCHOR PLATE (anchor bolts are not included) - AISI 304 | - | - | 3 |
| B1 | 1/2 FIXED LID - AISI 316 | - | - | 1 |
| C1 | 1/2 HINGED LID - AISI 316 | - | - | 1 |
| D1 | DISMOUNTABLE STATIC CIP SPRAY BALL Ø28 360° UP TO WELDING MALE NIPPLE 1/2" - AISI 316 | atm. | 1/2" | 1 |
| E1 | INLET FOR AGITATOR UP TO FLANGE Ø 220 s20 - AISI 316 | - | 100 | 1 |
| F1 | DISMOUNTABLE TOTAL OUTLET UP TO WELDING LINER AND NUT - AISI 316 | atm. | 40 | 1 |
| G1 | SAFETY GRID ON HINGED LID - AISI 316 | - | - | 1 |

| | | | | | |
|---------|---------|----|--------------|---------|-------------------------|
| Surface | Outside | 2B | Welding seam | Outside | strip grinded to Ra<1,6 |
| | Inside | 2B | | Inside | |

1.6 min. 0,5x45° **Not-indicated tolerances of dimensions of length and angles, shapes and positions are according to EN ISO 13920:2006**

| | | | | | |
|--|---------------------|------------|-----------|----------|-----------------------------|
| | Drawn.: K.N | Scale 1:12 | Mass 90.4 | AISI 316 | Order.Nº 115 095 07 |
| | Checket: K.I | | | AISI 304 | EW9229V6N/ID10.898-ID10.932 |

VERTICAL TANK TYPE VC-SLA Vtotal=0,2m3