

BEHALTER KG
BREMEN

Behälter KG Bremen GmbH & Co.
Theodor-Barth-Str. 25
28307 Bremen – Germany
Tel.: +49 421 34 85 10
Mail: mail@behaelter.kg.de

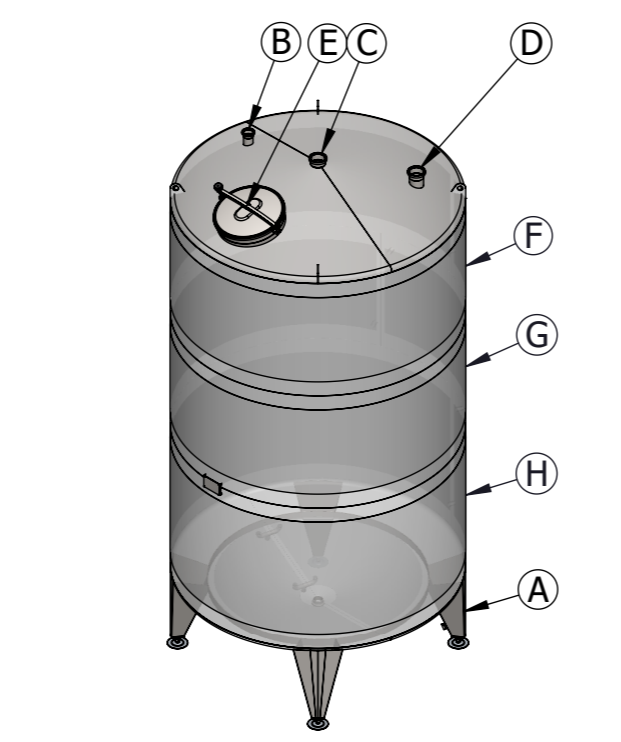

TYPE K3-H12W.L	
Serial number	117 915 17
Geometrical volume	12600 t
Working pressure	Atmospheric
Working temperature	-10/100°C
Maximum density	1.2kg/dm³
Tare mass	720 kg
Equipment output/voltage	-
Stock nr.	WW11.560V6LN
Geometrical volume - jacket	30 t
Working pressure - jacket	0/3 bar
Working temperature - jacket	-10/110°C
Jacket pressure drop	-
Material	1.4404/AISI 316L
Year of manufacture	-

Revisions					
Rev	Description	Zone	Date	Drawn	Checked

Item	Description	PN bar	DN mm.	Qty.
A	LEG ON ADJUSTABLE SUPPORT	-	-	4
B	INLET DN65 ON TANK TOP UP TO WELDING MALE DN65 DIN11851 + 2pcs NBR (perbunan) gasket for welding male DN65 DIN11851	atm.	65	1
C	INLET DN100 CENTRICALLY MOUNTED ON TANK TOP UP TO WELDING MALE DN100 DIN11851 + 2pcs NBR (perbunan) gasket for welding male DN100 DIN11851	atm.	100	1
D	INLET DN100 FOR AIRVENT ON TANK TOP UP TO WELDING MALE DN100 DIN11851 + 2pcs NBR (perbunan) gasket for welding male DN100 DIN11851*air vent is not included	atm.	100	1
E	UPPER MANHOLE DN500 Elica art.50/1p-4 EPDM-FDA GASKET	atm.	500	1
F	UPPER LASER-WELDED DIMPLE JACKET ON TANK SHELL H=750mm / F=4.95m² *heating agent hot water at Pmax=3bar and Tmax=110°C	3	-	1
G	MIDDLE LASER-WELDED DIMPLE JACKET ON TANK SHELL H=750mm / F=4.95m² *heating agent hot water at Pmax=3bar and Tmax=110°C	3	-	1
H	LOWER LASER-WELDED DIMPLE JACKET ON TANK SHELL H=1000mm / F=6.6m² *heating agent hot water at Pmax=3bar and Tmax=110°C	3	-	1
I	INLET/OUTLET DIMPLE JACKET ON TANK SHELL UP TO WELDING MALE G1"	3	G1"	6
J	LASER-WELDED DIMPLE JACKET ON TANK BOTTOM F=1.5m² *heating agent hot water at Pmax=3bar and Tmax=110°C	3	-	1
K	INLET/OUTLET DIMPLE JACKET ON TANK BOTTOM UP TO WELDING MALE G1"	3	G1"	2
L	TOTAL OUTLET DN65 UP TO WELDING MALE DN65 DIN11851 + 2pcs NBR (perbunan) gasket for welding male DN65 DIN11851	atm.	65	1

Straightness, flatness and parallelism - EN 13920 F								Linear dimensions - EN 13920 B							
≥30	>120	>400	>1000	>2000	>4000	>8000	>12000	≥2	>30	>400	>1000	>2000	>4000	>8000	>12000
≤120	≤400	≤1000	≤2000	≤4000	≤8000	≤12000	≤16000	≤30	≤400	≤1000	≤2000	≤4000	≤8000	≤12000	≤16000
1	1.5	3	4.5	6	8	10	12	±1	±2	±3	±4	±6	±8	±10	±12

Surface	Outside		Matt 2B		Weld. seams	Outside		Strip grinded 2x20 Ra<1,6	
	Inside		Matt 2B			Inside		Flat grinded to Ra<0,8	
1.6	✓	✓	✓	✓	✓	✓	✓	✓	✓

Drawn: **S.S.** Scale 1:55 Weight 720 1.4404/AISI 316L 117 915 17 WW11.560V6LN
 Checked: **K.I.** S11560 TYPE K3-H12W.L-12600L
 Approved: **D.M.**

Rev	23.11.2018 r.	Lang Eng	Sheet 1/1
-----	---------------	----------	-----------