

Revisions					
Rev	Description	Zone	Date	Drawn	Checked
A	Remove the elliptical manhole. Change the name of the tank. Change stock numbers.		10.09.18		

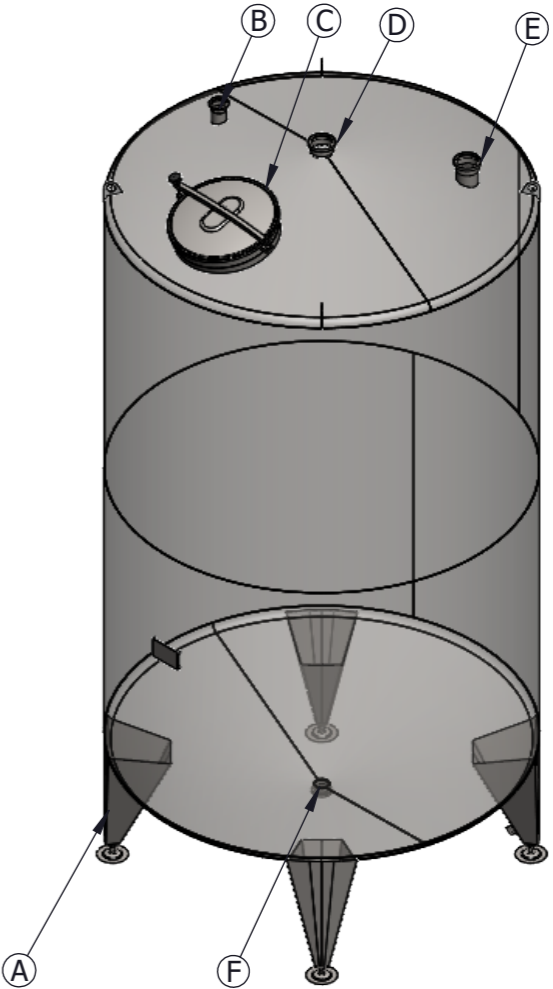

Behälter KG Bremen GmbH & Co.  
 Theodor-Barth-Str. 25  
 28307 Bremen – Germany  
 Tel.: +49 421 34 85 10  
 Mail: [mail@behaelter-kg.de](mailto:mail@behaelter-kg.de)

TYPE K3-SL			
Serial number	118 166 05 01	Stock nr.	EW11.333V6LN / ID16.397
Geometrical volume	10300 l	Geometrical volume - jacket	-
Working pressure	Atmospheric	Working pressure - jacket	-
Working temperature	-10/80°C	Working temperature - jacket	-
Maximum density	1.2kg/dm³	Jacket pressure drop	-
Tare mass	484 kg	Material	1.4404 / AISI 316L
Equipment output/voltage	-	Year of manufacture	2018

TYPE K3-SL			
Serial number	118 166 05 02	Stock nr.	EW11.333V6LN / ID16.398
Geometrical volume	10300 l	Geometrical volume - jacket	-
Working pressure	Atmospheric	Working pressure - jacket	-
Working temperature	-10/80°C	Working temperature - jacket	-
Maximum density	1.2kg/dm³	Jacket pressure drop	-
Tare mass	484 kg	Material	1.4404 / AISI 316L
Equipment output/voltage	-	Year of manufacture	2018

Item	Description	PN	DN	Qty.
		bar	mm.	
A	LEG ON ADJUSTABLE SUPPORT	-	-	4
B	INLET DN65 ON TANK TOP UP TO WELDING MALE DN65 DIN 11851	atm.	65	1
C	UPPER MANHOLE DN500 Elica art. 50/1p-6 WITH EPDM-FDA-GASKET	atm.	500	1
D	INLET DN100 CENTRICALLY MOUNTED ON TANK TOP UP TO WELDING MALE DN100 DIN 11851	atm.	100	1
E	INLET AIR VENT DN100 ON TANK TOP UP TO WELDING MALE DN100 DIN 11851	atm.	100	1
F	TOTAL OUTLET DN65 UP TO WELDING MALE DN65 DIN 11851	atm.	65	1

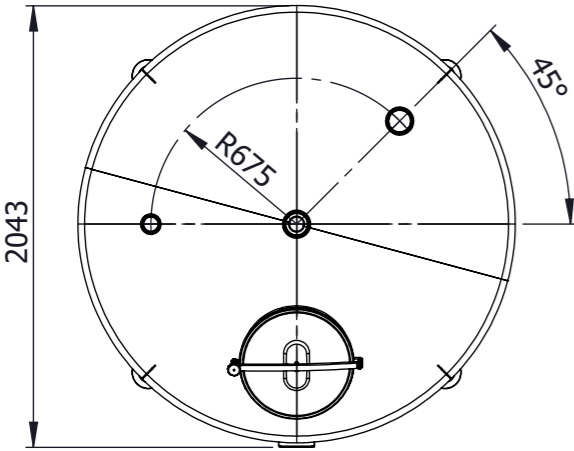

Straightness, flatness and parallelism - EN 13920 F								Linear dimensions - EN 13920 B											
≥30 ≤120	>120 ≤400	>400 ≤1000	>1000 ≤2000	>2000 ≤4000	>4000 ≤8000	>8000 ≤12000	>12000 ≤16000	≥2 ≤30	>30 ≤400	>400 ≤1000	>1000 ≤2000	>2000 ≤4000	>4000 ≤8000	>8000 ≤12000	>12000 ≤16000				
1	1.5	3	4.5	6	8	10	12	±1	±2	±3	±4	±6	±8	±10	±12				
Surface		Outside		Matt 2B		Weld. seams		Outside		Strip grinded 2x20 Ra<1,6									
		Inside		Matt 2B				Inside		Strip grinded 2x20 Ra<1,6									
1.6		✓/✓/✓		Drawn: K.N.		Scale 1:35		Weight 484		1.4404/ AISI316L		118 166 05 EW11.333V6LN / ID16.397- ID16.398							
✓/✓/✓		Checked: K.I.		S11333 TYPE K3-SL-10300L								Rev		10.9.2018 r.		Lang Eng		Sheet 1/1	
✓/✓/✓		Approved: D.M.																	