

Stutzen	Größe	Funktion	Bemerkung	Position
N1	440 x 330 mm	ovaler Mannlochverschluss		90°
N2	Ø 300	Rührwerksflansch DN 300 PN 10		270°
N3	Ø 600	Domdeckel Ø 600 mm	zum Einbringen Rührwerk	330°
N4	DN 65	Restentleerung	Losflansch	0°
N5	DN 65	Rücklauf		300°
N6	DN 80	Erlüftung		135°
N7	DN 80	Reservestutzen		180°
N8	1/2"	Muffe		290°
N9	1/2"	Muffe		310°
N10	1/2"	Muffe		10°
N11		Aufliegekufen		180°
N12		Beheizung		225°
N13		Aufstiegseiter		330°
N14		Schaltschrank		0°
N15		Kranösen		90°, 270°
N16		Isolierung 100 mm		
N17		Edelstahl Bodenblech 5 mm		
N18		Edelstahl Mantelblech 4 mm		
N19		Edelstahl Deckblech 4 mm		
N20		Edelstahl Außenmantel 3 mm		
N21		Edelstahl Flachstahl 120 x 10 mm	Verstärkung Bodenblech	

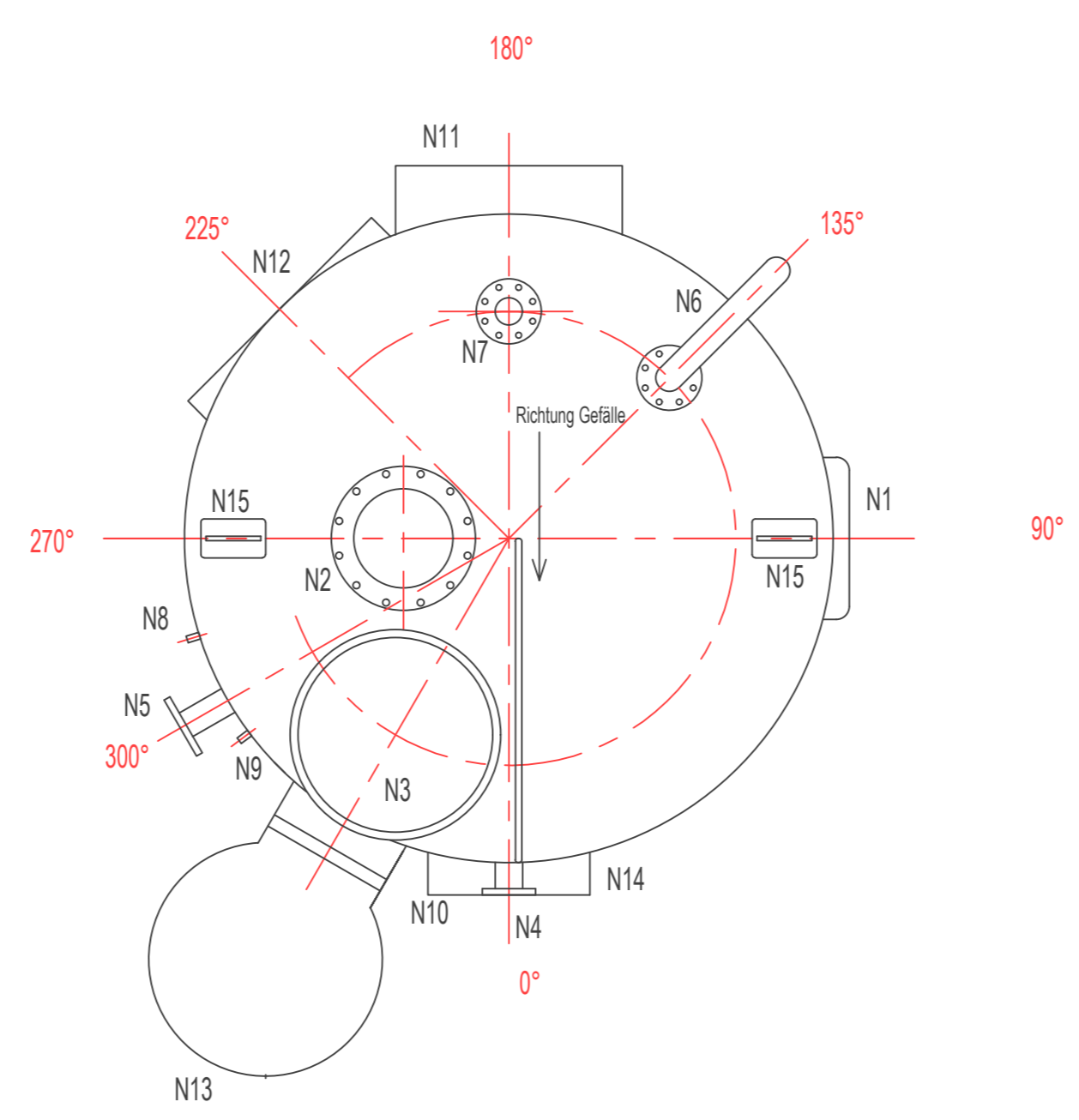

Leergewicht Rührtank 3.250 kg
 Leergewicht Wanne 1.150 kg
 Grundfläche Füße 120 x 120 mm
 Fussabstand 1.330 mm

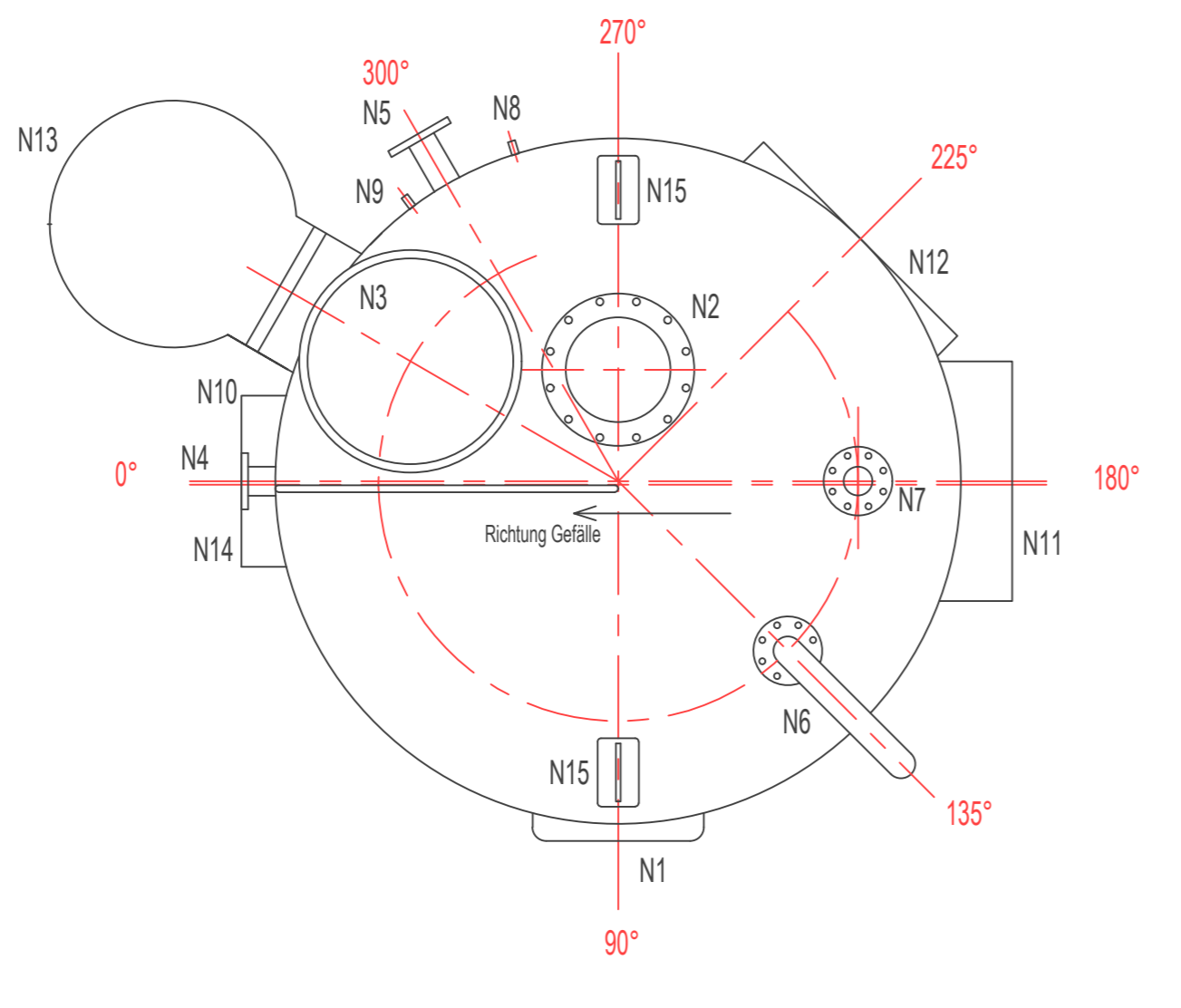
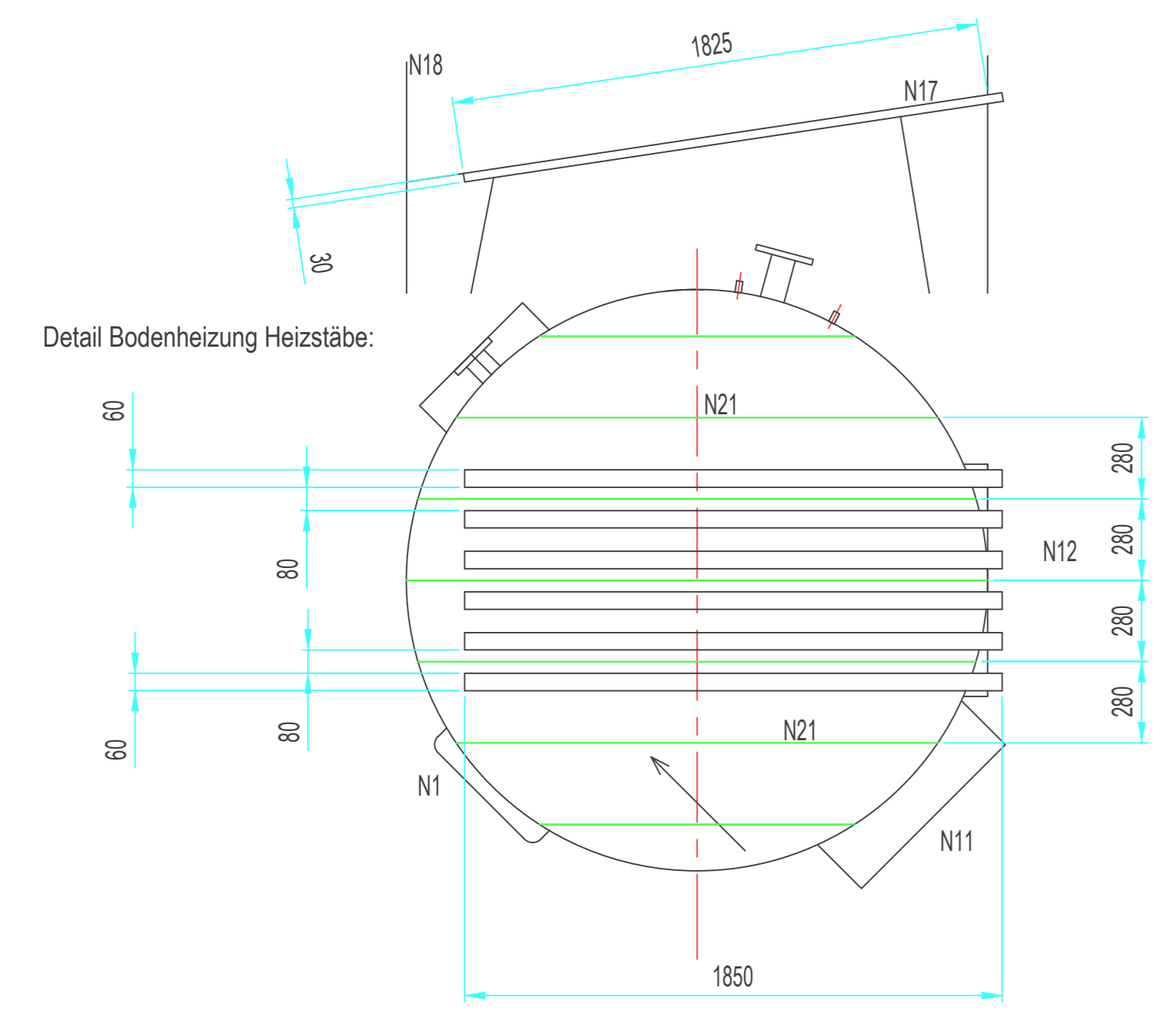
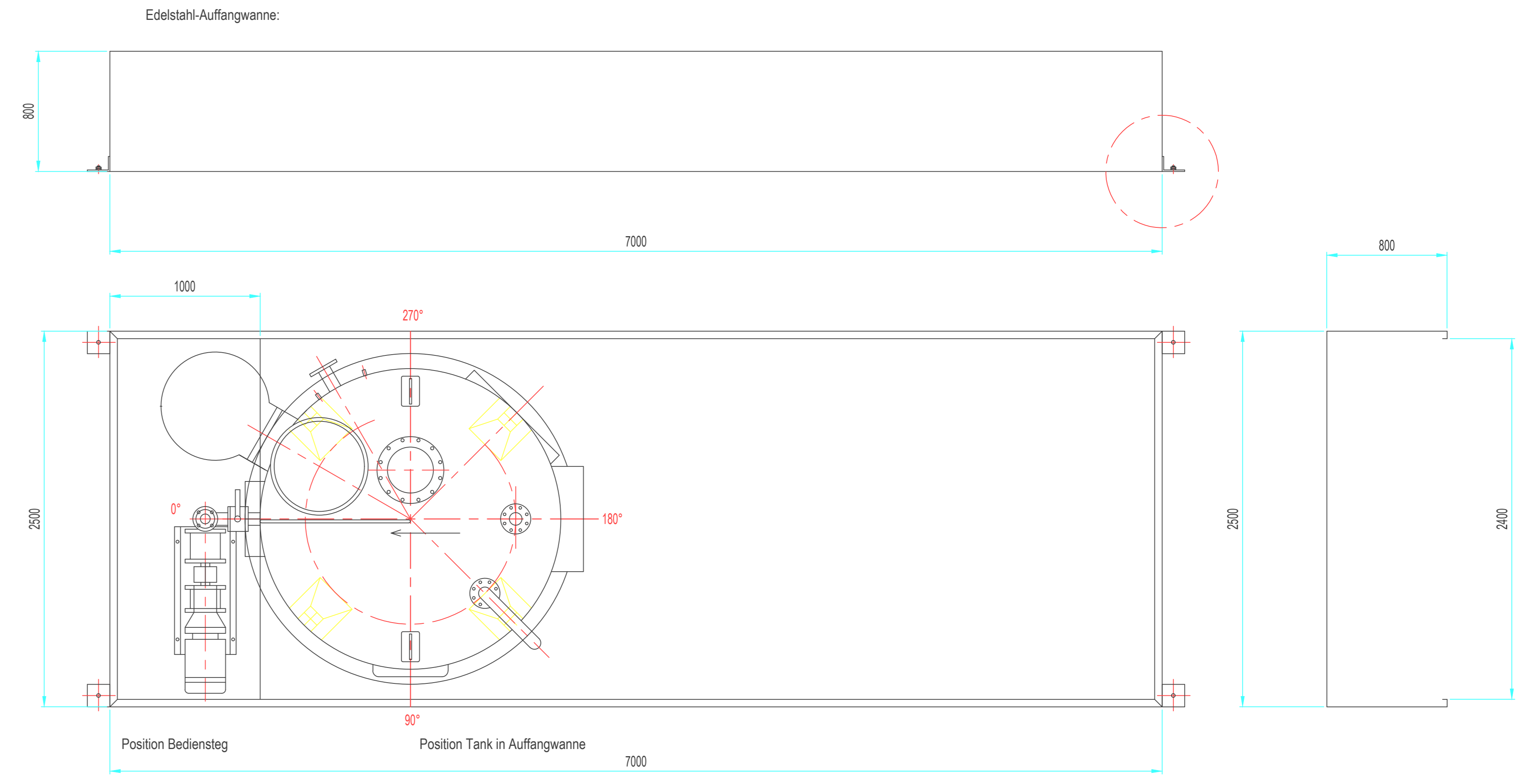
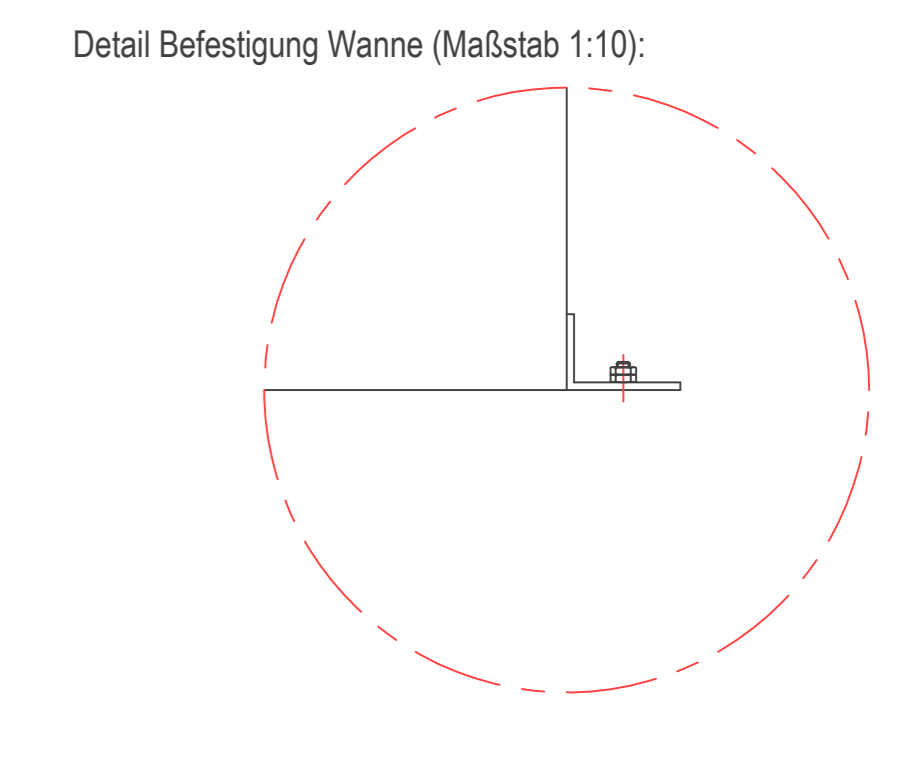
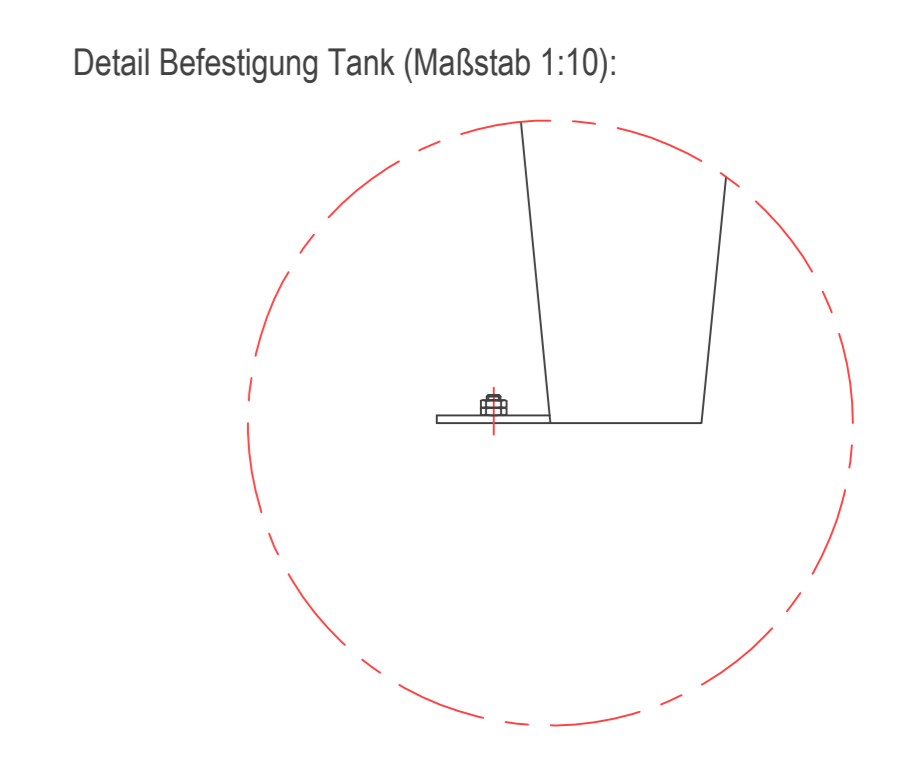