

Item Quant.	Part Description	Description
1	1 Inside body Length 2000 T.C 15M3 th. 6 mm	Inox AISI 304L (1.4307)
2	1 Inside body Length 1400 T.C 15 M3 th. 6 mm	Inox AISI 304L (1.4307)
3	2 Inside top 15M3 th. 6 mm	Inox AISI 304L (1.4307)
4	17 Reinforcement between inner and outer body th. 4 mm	Inox AISI 304L (1.4307)
5	1 Outside body Length 2000 T.C 15 M3 (1 manhole) th. 4 mm	Inox AISI 304L (1.4307)
6	1 Outside body Length 1400 T.C 15 M3 th. 4 mm	Inox AISI 304L (1.4307)
7	2 Outside top 15M3 th. 5 mm	Inox AISI 304L (1.4307)
8	1 Collar DN 500 T.C 15 M3 th. 6 mm	Inox AISI 304L (1.4307)
9	1 Flange din 2576 DN 500	Inox AISI 304L (1.4307)
10	1 Blank Flange DIN 2527 DN 500 T.C 15 M3	Inox AISI 304L (1.4307)
11	40 Washer M 24	Inox AISI 304L (1.4307)
12	20 Hex bolt M 24 x 110	Inox AISI 304L (1.4307)
13	20 Hex nut M 24	Inox AISI 304L (1.4307)
14	1 Maximum level device G 1 1/2"	Inox AISI 304L (1.4307)
15	1 Unloading pipe DN 50 PN 10	Inox AISI 304L (1.4307)
16	1 Return DN 50 PN 10 pipe ø 33.7 mm	Inox AISI 304L (1.4307)
17	1 Vent Pipe DN 50 T.C 15 M3	Inox AISI 304L (1.4307)
18	1 Loading pipe DN 65 ø76.1 X 2,6 mm	Inox AISI 304L (1.4307)
19	1 Body Closure th. 4 mm	Inox AISI 304L (1.4307)
20	1 Vacuum Gauge (leak control) G 1"	Inox AISI 304L (1.4307)
21	2 Profile L 50x50 mm	Inox AISI 304L (1.4307)

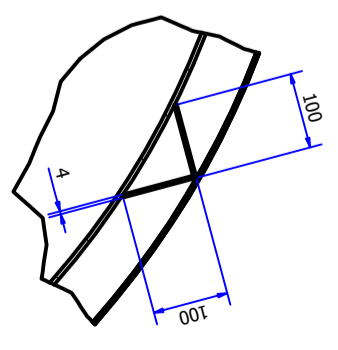
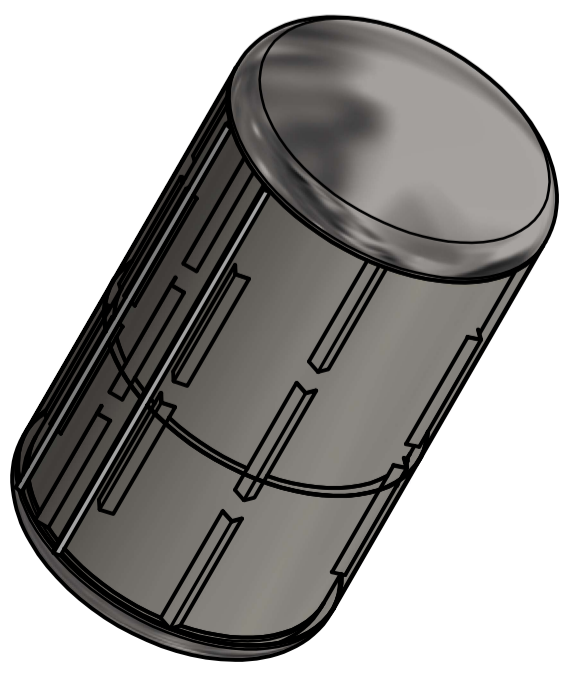
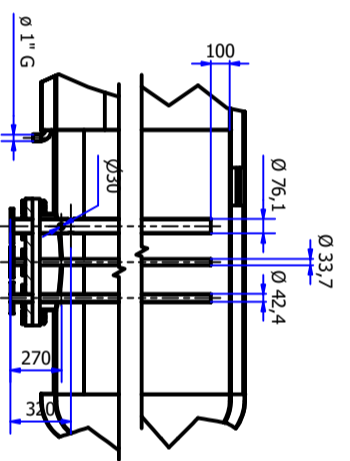
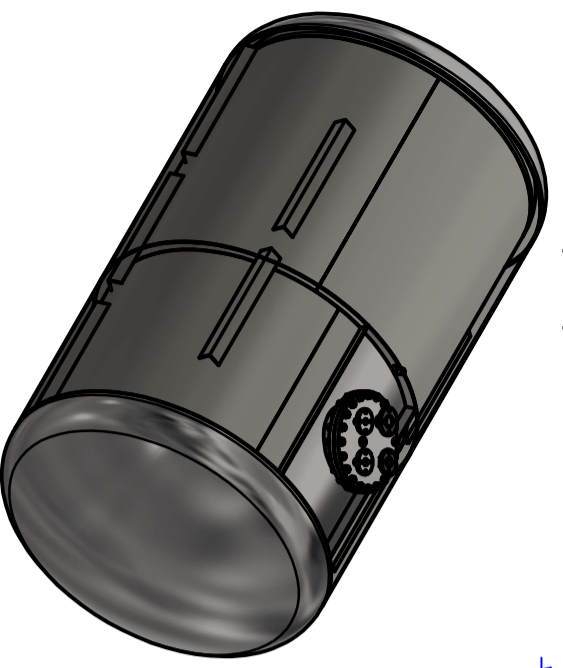
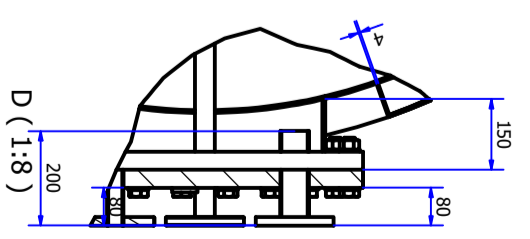
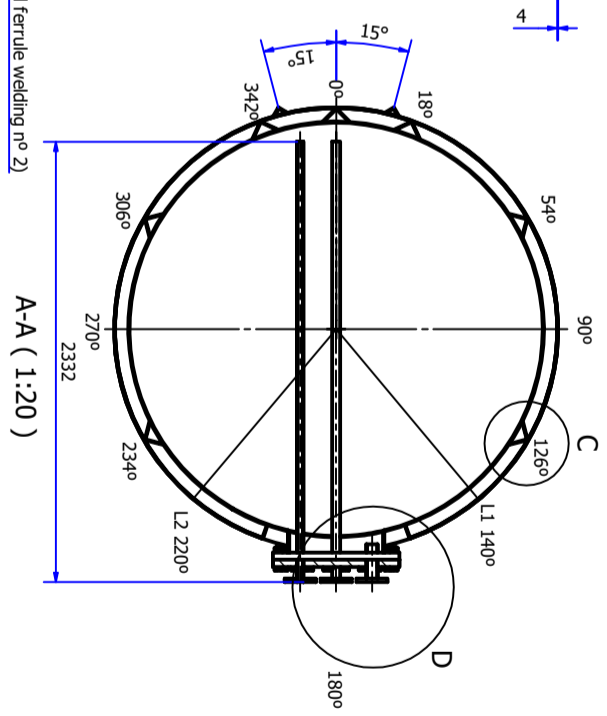
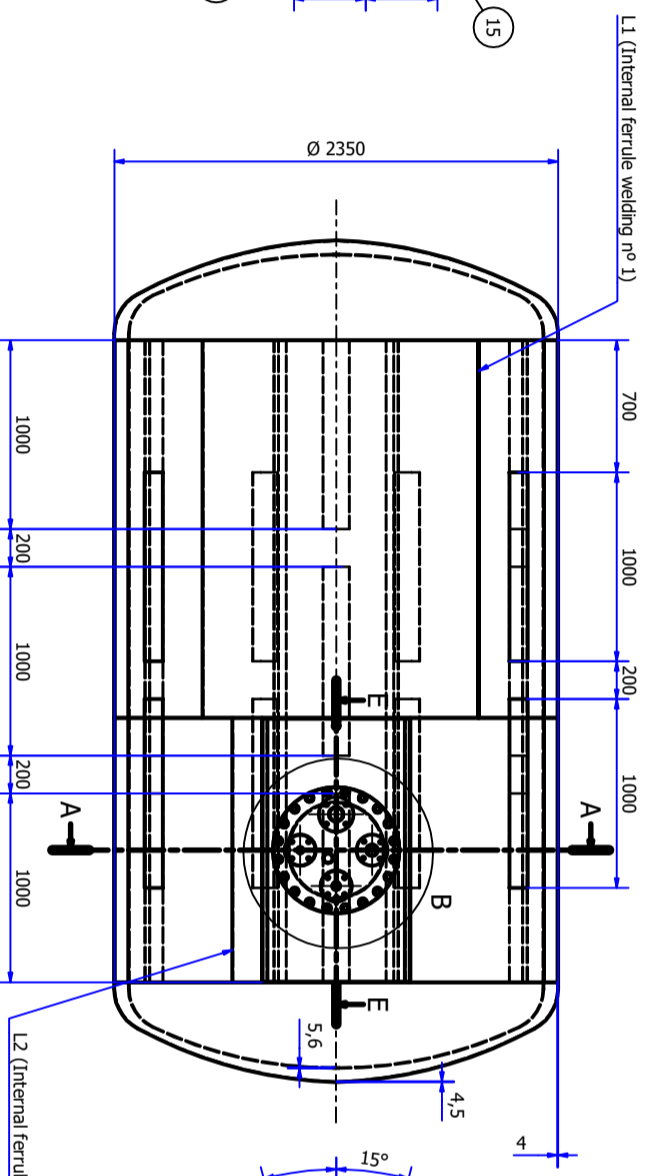
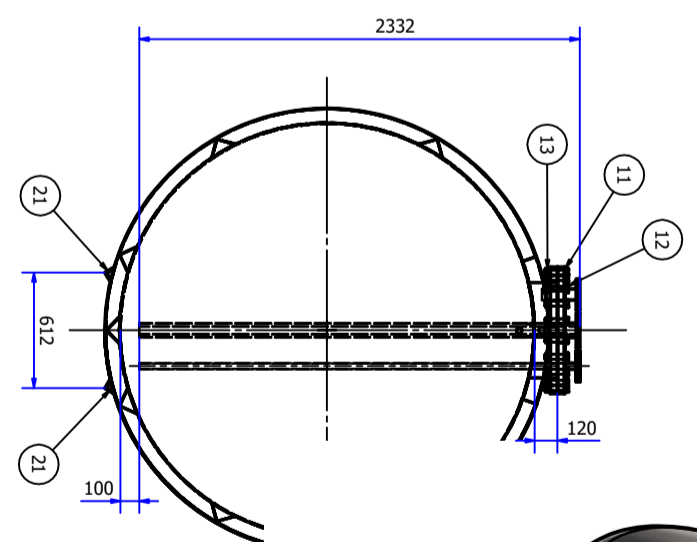
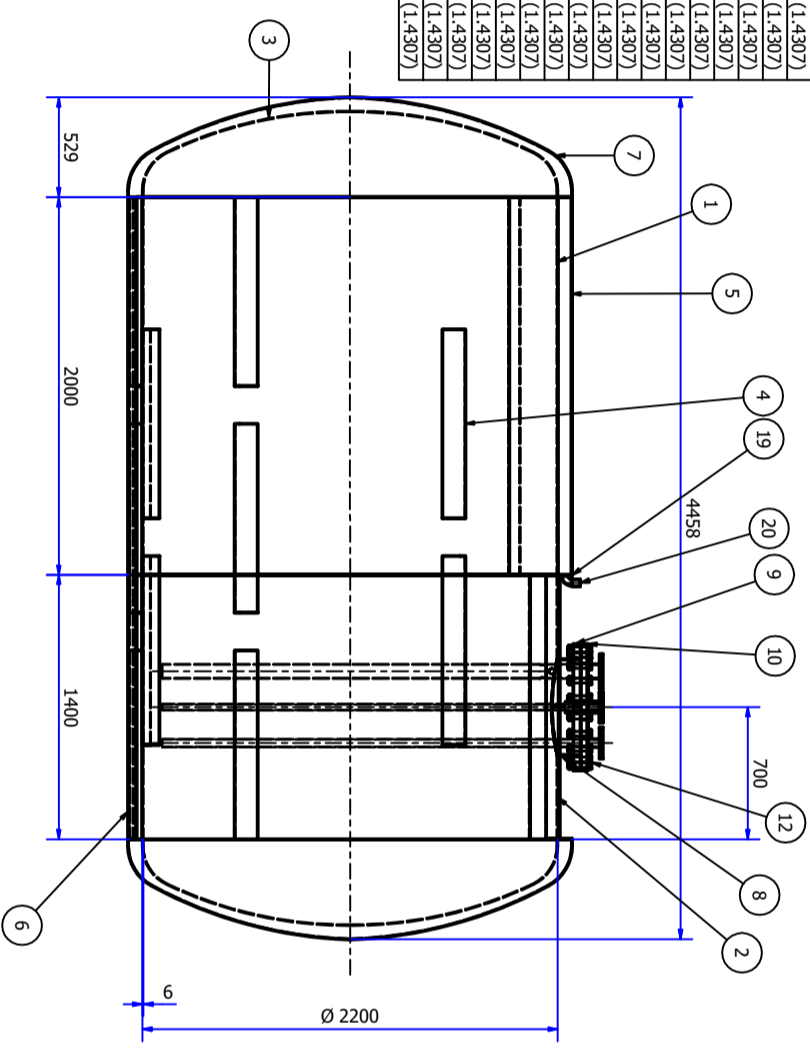

OUTSIDE FINISH: 1D washed and passivated welds  
 INSIDE FINISH: 1D washed and passivated welds  
**Quantity: 6**

<b>Designed by:</b> Rui Tavares	<b>Created on:</b> 27/03/2019	<b>Rev.:</b> A1
<b>JOTAINOX</b>		
<b>Client:</b> SOLVENT STORAGE TANK 15 M3	Solvent Storage Tank 15 M3 (1 Manhole) - Rev. 4	
<b>Nº Drw.:</b> 51	<b>Scale:</b> 20	<b>Sheet of:</b> 1