

LID TOP VIEW

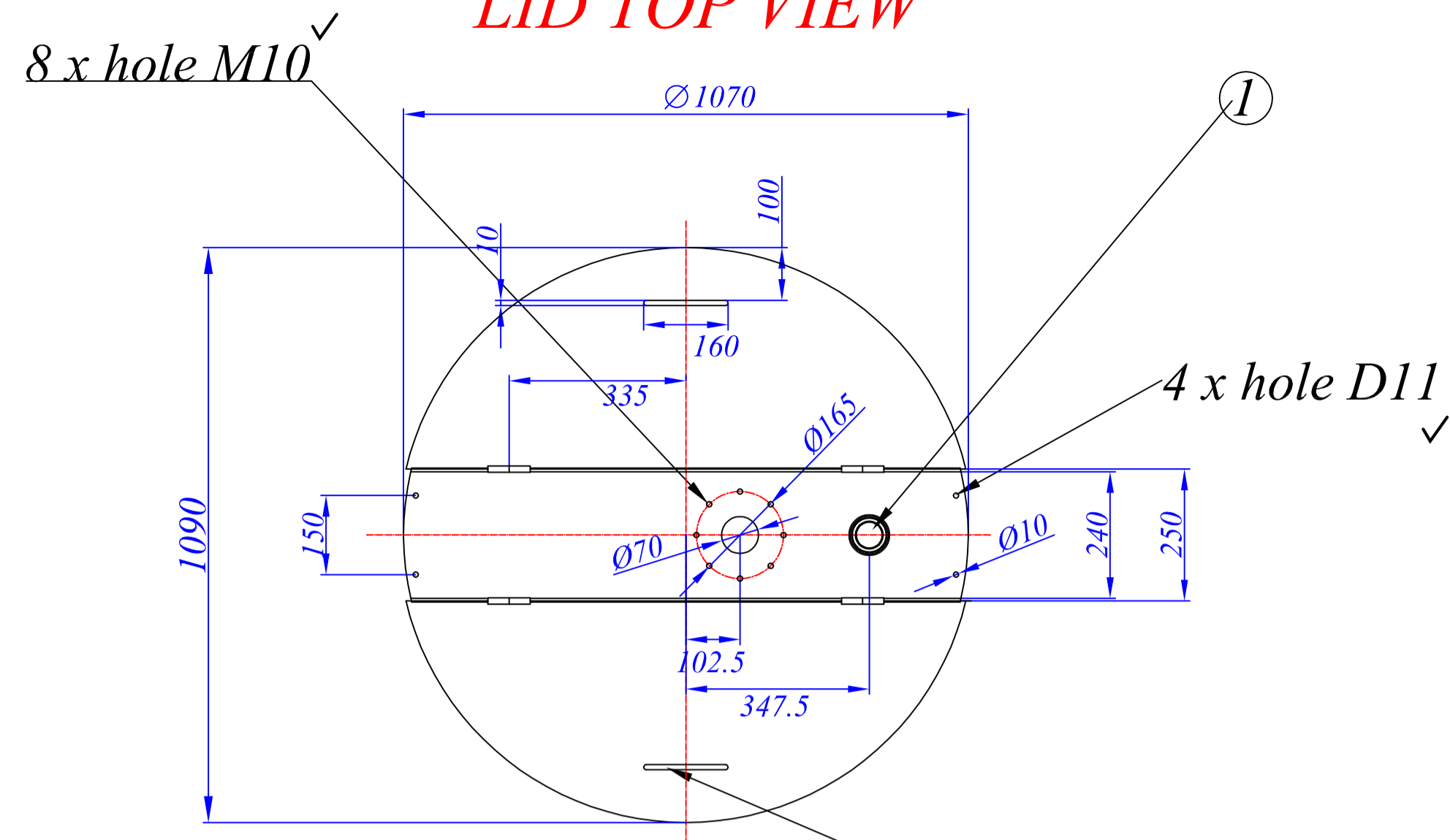

LID SITE VIEW

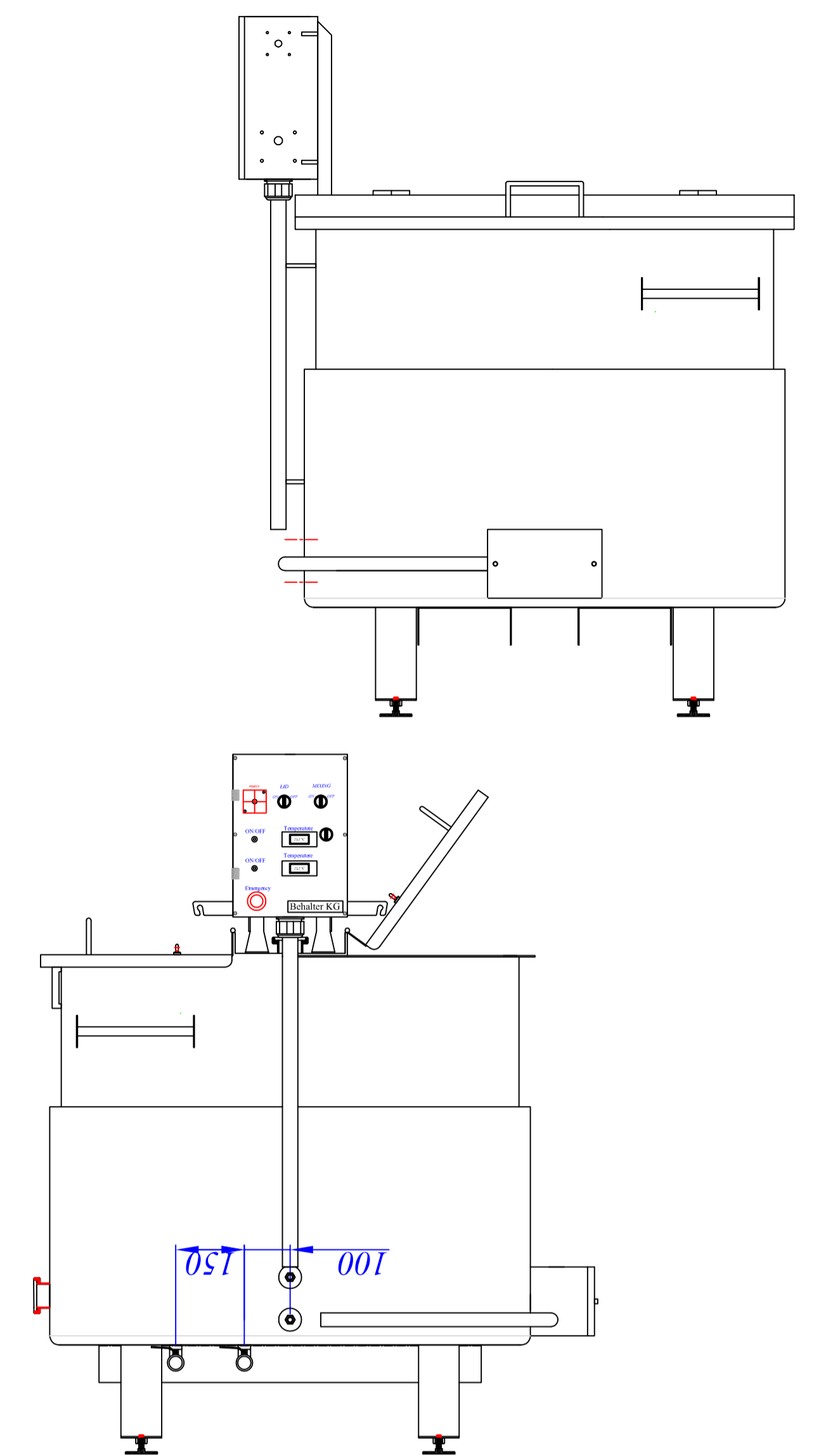
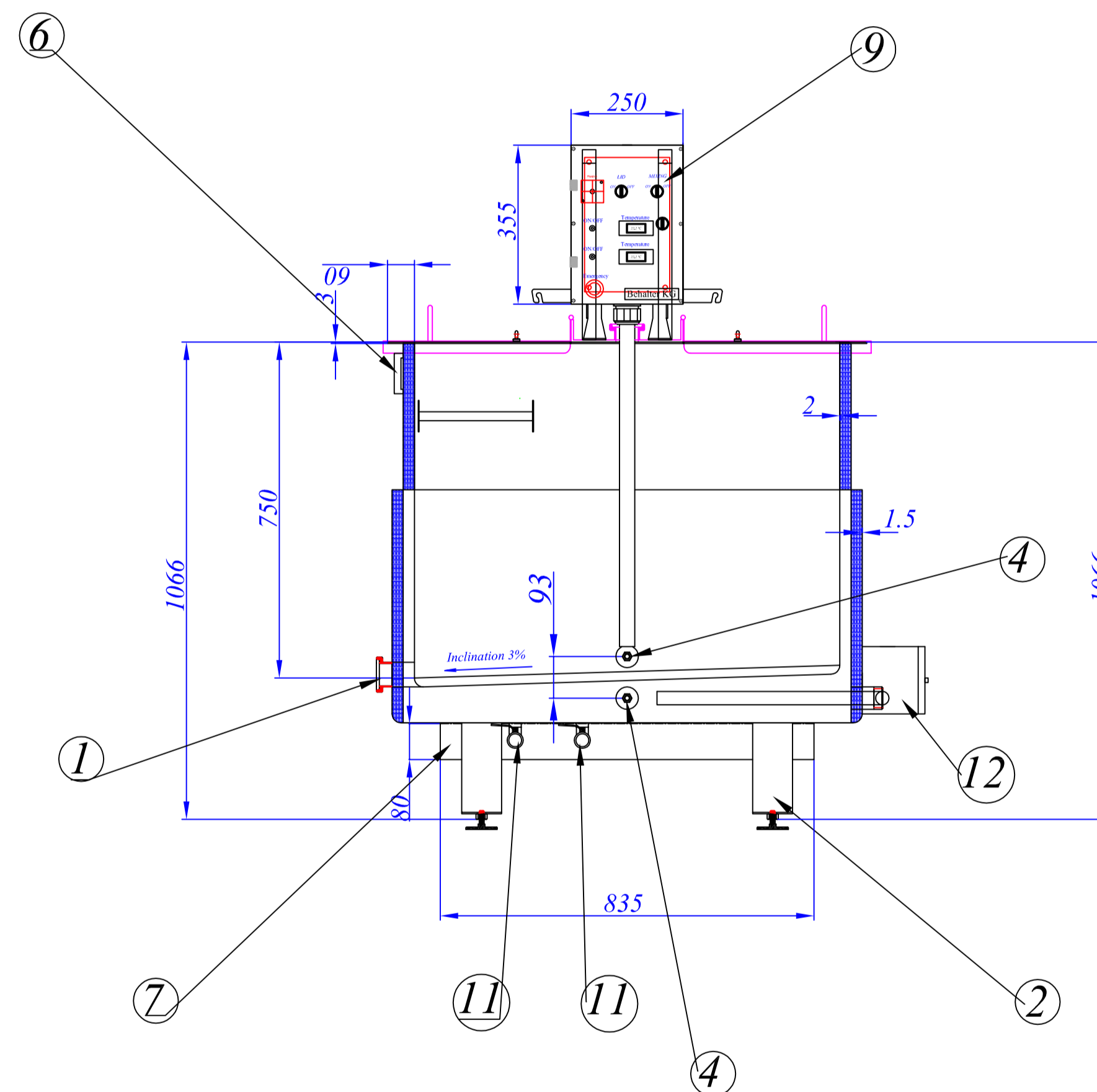
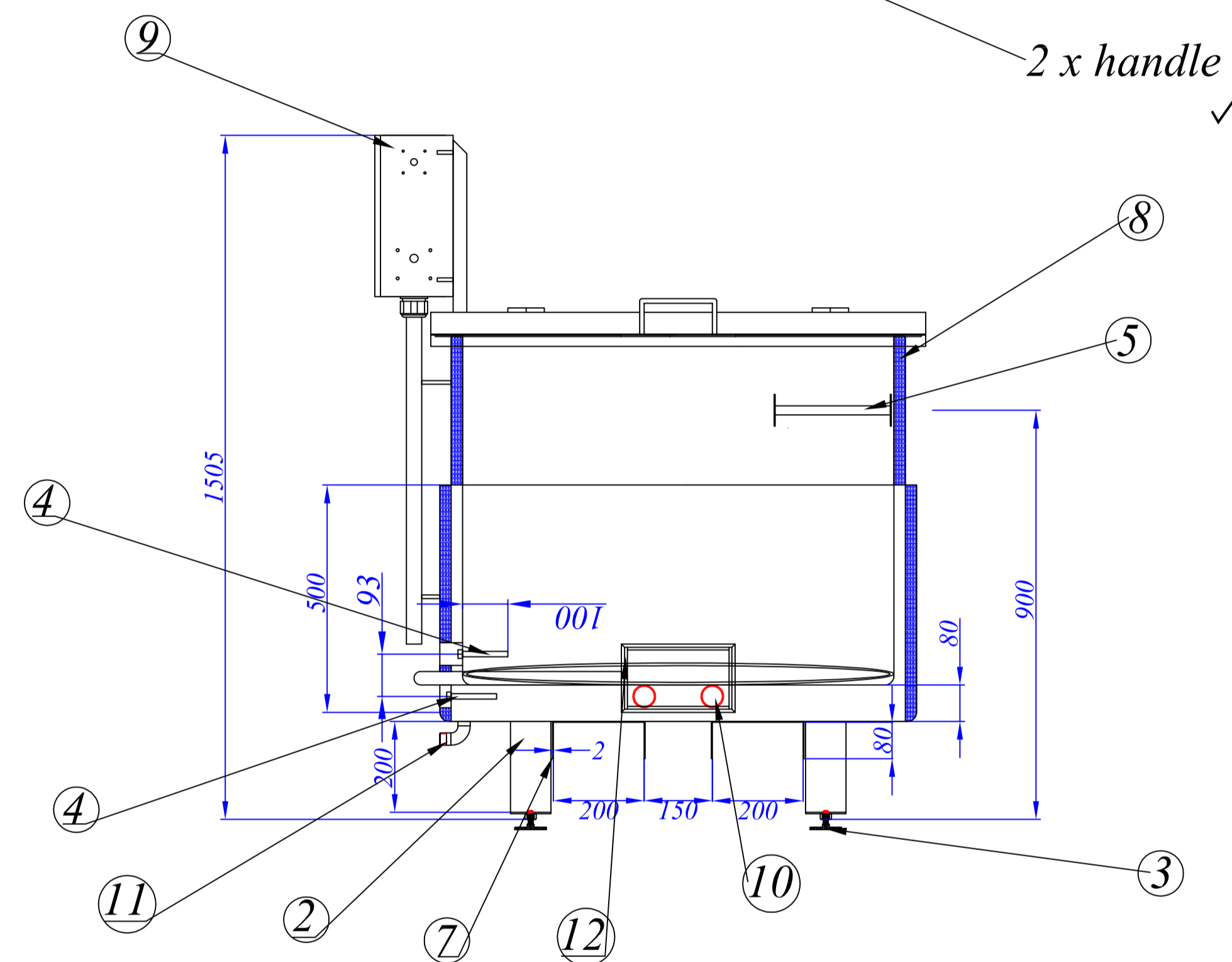
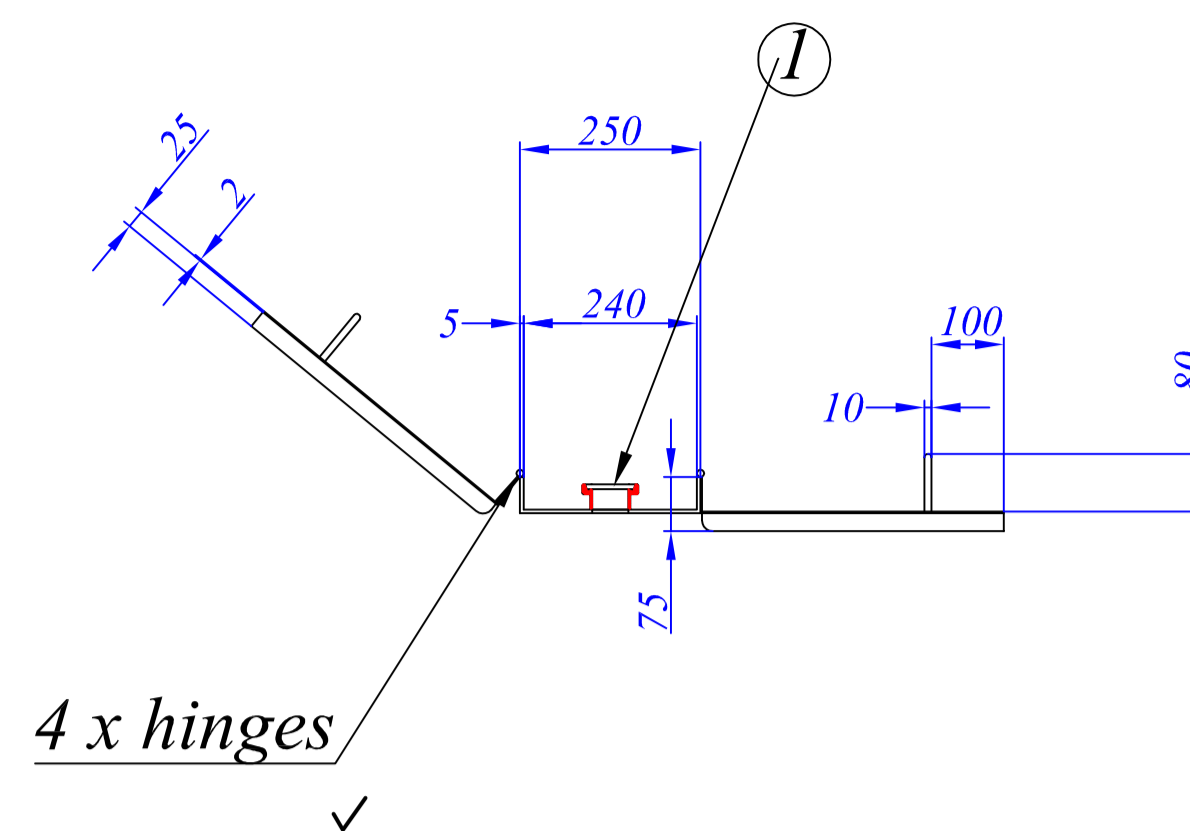

TANK TOP VIEW

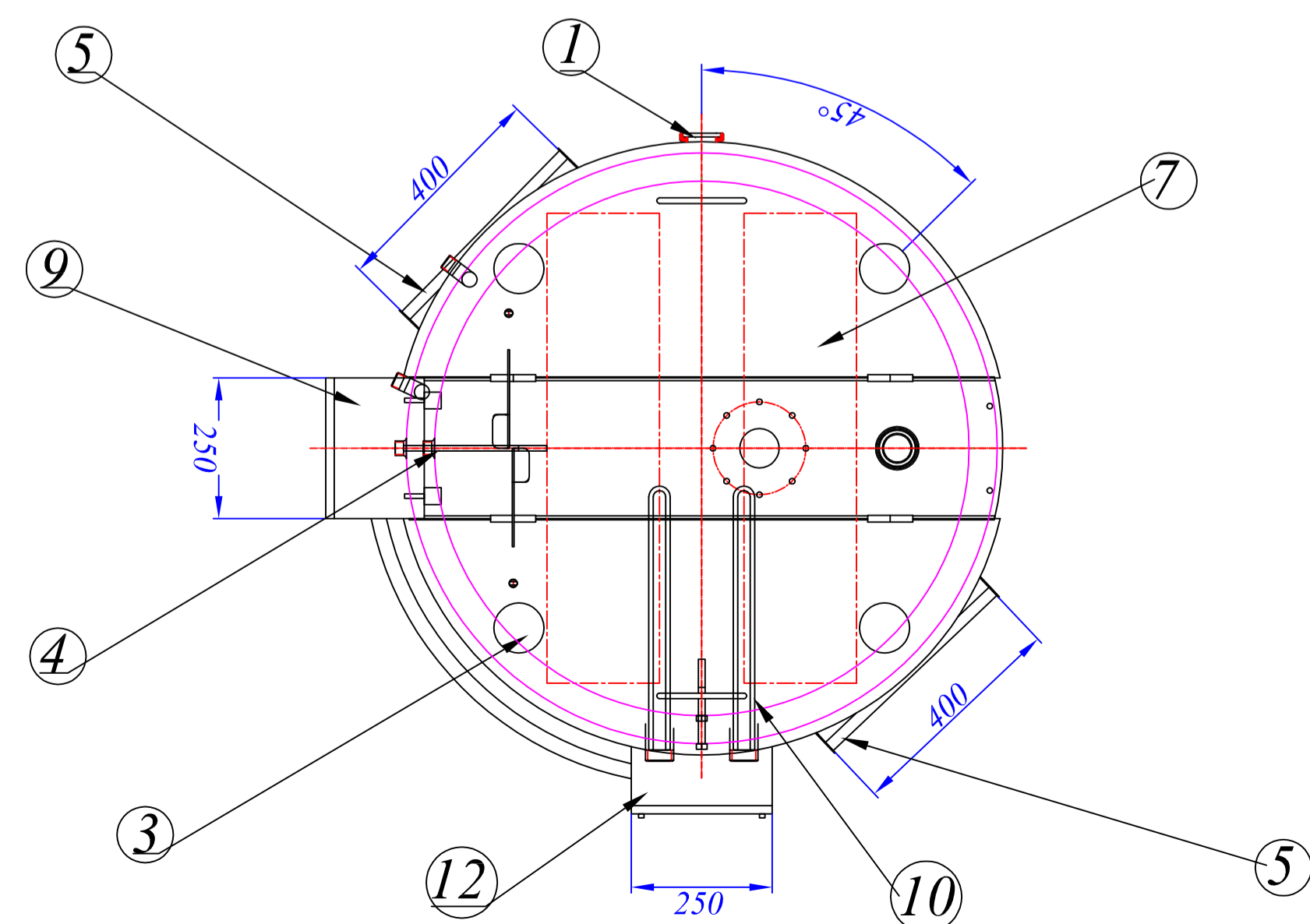

- material **AISI 316** for the internal tank ✓
- outside surface are **SBR scotch brite** ✓
- inside surface are make with grinding whell and than high polish ($Ra = 0,8$) ✓
- Tickness of material for the internal tank 2 mm ✓
- Tickness of material for the external tank 1,5 mm ✓

Item	Description	Pressure bar	DN mm	Qty.
1	Male DN50 DIN11851 ✓	atm.	50	2
2	Leg hight 200 mm ✓	—	—	4
3	Adjustable legs M16 ✓	—	M16	4
4	Probe PT100 with Nut M12 ✓	atm.	M12	2
5	Stainless stell handle ✓	—	—	1
6	Stainless stell plate with logo and technical data	—	100X80	1
7	Forklift tunnels ✓	atm.	80x200	2
8	Insulation Rockwool 25 mm ✓	—	25	2
9	General stainless stell cabinet 3 phase ✓	—	—	1
10	Electrical heater 6 kW ✓	—	BSP5/4"	2
11	Inox ball valve BSP3/4" ✓	atm.	26,9	2
12	Electrical cabinet for heaters ✓	—	—	1

Poz	Predmet in mere			Kos	Material	Masa	Standard	Klasif. / Št. risbe
	Dne	Ime	Podpis		Material			
Konst.					AISI 316 BA internal surface : high polish external surface : SBR			
Risal	26.2.2021	Lozej Andrej			Masa			
Pregl.		Lozej Ivo						
Merilo	Naziv							
Order number:	01/03/2021							
Nr. pc.:	Client stamp and signature:							
3 pieces								
1:10	Open type tank 530 L							
							Št. risbe 02/26-02/2021	List 1